

## FITTING INSTRUCTION

Clamp mark in acc. with		Cables joining
ISO	PN	
1	L	Left directional lights
2	+	Rear fog lights
3	31	Ground
4	R	Right directional lights
5	58R	Right side parking lights
6	54	Stoplights
7	58L	Left side parking lights

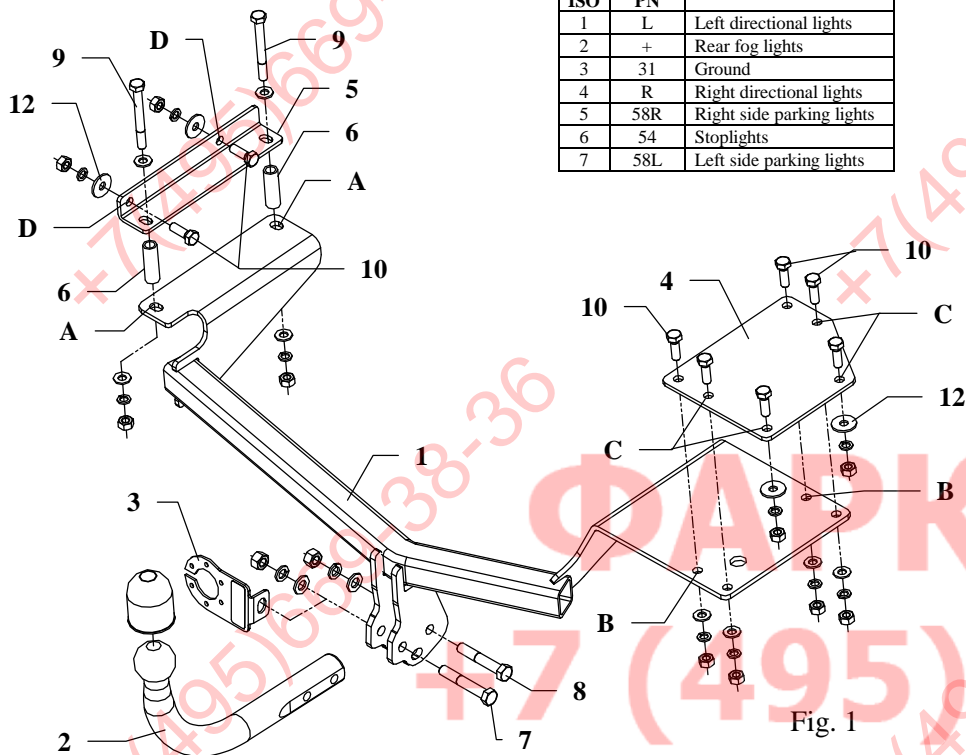

Fig. 1

This towing hitch is designed to assembly in following car: **SUZUKI SPLASH** and **OPEL AGILA**, both produced since 2008, catalogue no. **W28** and is prepared to tow trailers max total weight **800 kg** and max vertical mass **50 kg**.

### The instruction of the assembly

1. Inside trunk disassemble rear and side panels, next disassemble carpet of wheel's cover.
2. Remove plastic plugs underneath the bumper.
3. Disassemble last muffler's handle and slacken heatproof plate.
4. Inside trunk find dingoes at points A and B. Next drill it using bit  $\varnothing 11\text{mm}$ .
5. Enlarge holes A to dimension  $\varnothing 18\text{mm}$  (only from trunk's side!), see fig 2.
6. On the left side drill wanting hole according to figure 2.

7. In the trunk put distance sleeves (pos. 6) in to holes A ( $\varnothing 18\text{mm}$ ) and apply left fish-plate (pos. 5). Next put bolts M10x90mm (pos. 9).
8. On the right side, on holes B put right fish-plate (pos. 4) and next drill in trunk's floor wanting holes C using bit  $\varnothing 11\text{mm}$ .
9. Cut out fragments of the bumper:
  - Opel Agila** – in axis, underneath, width 55mm and depth 25mm,
  - Suzuki Splash** - in axis, underneath, width 55mm and depth 40mm.
10. Underneath the car apply main bar of the towbar (pos. 1) and fix with installed already elements in accordance to figure 1.
11. Through holes D of left fish-plate (pos. 5) drill holes  $\varnothing 11\text{mm}$ . Fix element using bolts M10x30mm (pos. 10) as shown on the figure 1.
12. Fix tow-ball (pos. 2) with socket plate (pos. 3) using bolts M12x75mm (pos. 7) and M12x70mm (pos. 8) from accessories.
13. Reassemble disassembled elements.
14. Connect electric wires of 7-poles socket according to the instruction of the car. (Recommend to make at authorized service station).
15. Complete paint layer damaged during installation.

Fig. 2

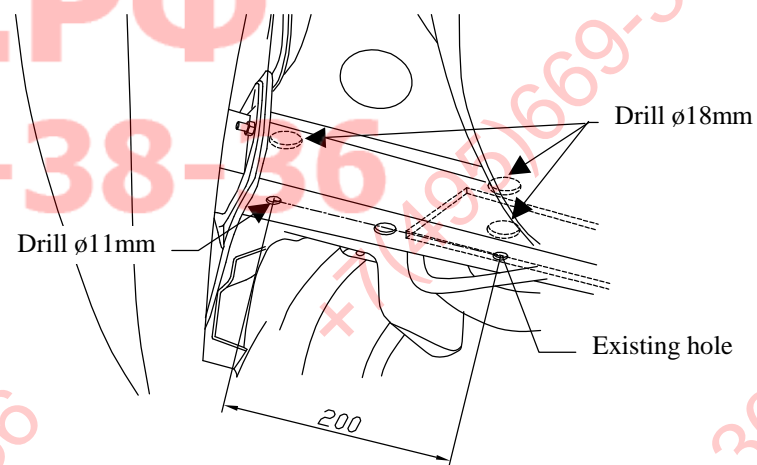

### NOTE

After install the towing hitch you should get adequate note in registration book (at authorised service station). The car should be equipped with:

- Indicators
- Tow mirrors

After 1000km of exploitation check all bolts and nuts. The ball of towing hitch must be always kept clear and conserve with a grease.



**Towing hitch accessories:**

Pos. 1 Main bar PCS.: 1	Pos. 5 Left fish-plate PCS.: 1	Pos. 10 Bolt 8,8 B M10x30mm PCS.: 8	Pos. 15 Spring washer ø10,2mm PCS.: 10
Pos. 2 Tow ball PCS.: 1	Pos. 6 Distance sleeve ø17,2x2,35mm L=52mm PCS.: 2	Pos. 11 Plain washer ø13mm PCS.: 2	Pos. 16 Nut 8 B M12 PCS.: 2
Pos. 3 Socket plate PCS.: 1	Pos. 7 Bolt 8,8 B M12x75mm PCS.: 1	Pos. 12 Plain washer ø30xø10,5x2,5mm PCS.: 4	Pos. 17 Nut 8 B M10 PCS.: 10
Pos. 4 Right fish-plate PCS.: 1	Pos. 8 Bolt 8,8 B M12x70mm PCS.: 1	Pos. 13 Plain washer ø10,5mm PCS.: 8	Pos. 18 Ball cover PCS.: 1
	Pos. 9 Bolt 8,8 B M10x90mm PCS.: 2	Pos. 14 Spring washer ø12,2mm PCS.: 2	

Fig. 3

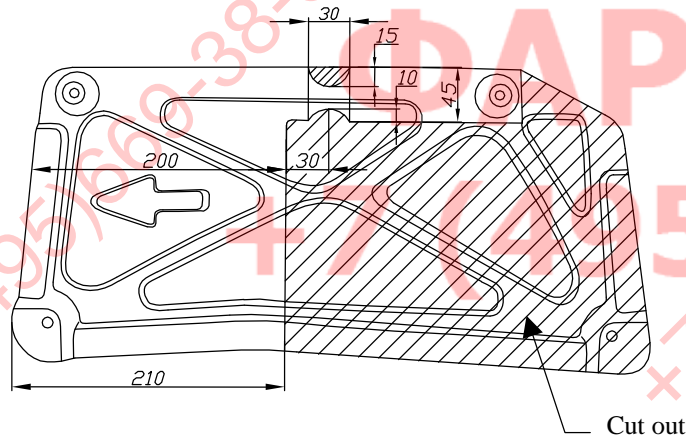
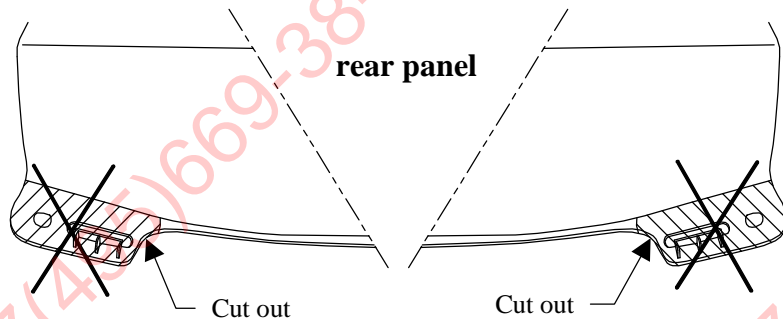

Fig. 4



**Towing hitch (without electrical set)**

Class: **A50-X** Cat. no. **W28**

Designed for:

Manufacturer: **SUZUKI**

Model: **SPLASH** and

Manufacturer: **OPEL**

Model: **AGILA**

both produced since 2008

Technical data:

**D-value: 4,5 kN**

maximum trailer weight: **800 kg**

maximum vertical cup mass: **50 kg**

Approval number according to Directive 94/20/EC: **e20\*94/20\*0733\*00**

**NOTE!**

Before start of installation always refer to vehicle's technical manual prior to install and use towbar to make sure that the particular Opel Agila / Suzuki Splash you are working on is prepared for this. Not all models Opel Agila / Suzuki Splash are prepared for towbar use!

**Foreword**

This towing hitch is designed according to rules of safety traffic regulations. The towing hitch is a safety component and can be install only by qualified personnel. Any alteration or conversion of the towing hitch is prohibited and would lead to cancellation of design certification. Remove insulating compound and underseal from vehicle (if present) in the area of the matting surfaces of the towing hitch.

The vehicle manufacturer's specifications regarding trailer mass and max. vertical cup mass are decisive for driving whereat values for the towing hitch cannot be exceeded.

D-value formula:

$$\frac{\text{Max trailer weight [kg]} \times \text{Max vehicle weight [kg]}}{\text{Max trailer weight [kg]} + \text{Max vehicle weight [kg]}} \times \frac{9,81}{1000} = D \text{ [kN]}$$